

S

VA11

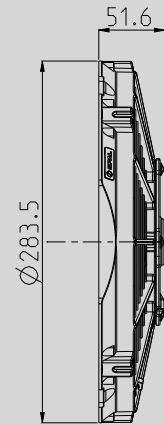
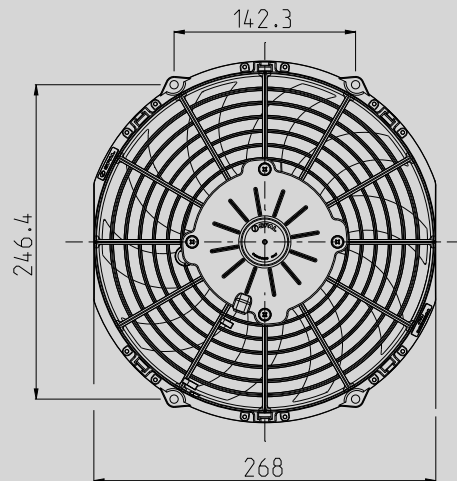
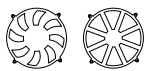

VA11-BP12/C-57S

VA11-BP8/C-29S

pressure [Pa]	VA11-BP12/C-57S		VA11-BP8/C-29S	
	airflow [m³/h]	current input [A]	airflow [m³/h]	current input [A]
0	1.415	3,5	1.161	3,1
25	1.317	3,6	1.070	3,2
50	1.209	3,7	967	3,2
75	1.073	3,9	872	3,3
100	903	3,9	709	3,3
125	703	3,9	495	3,4
150	508	3,8	284	3,3
175	272	3,5	124	3,4
200	134	3,6	0	3,5
225	25	3,7		
250	0	3,8		
275				
300				
325				

GENERAL INFORMATION

● VA11-BP12/C-57S

Weight	1,00 Kg
Mounting torque	3 Nm (+1/0) with screw M5

● VA11-BP12/C-29S

Weight	1,00 Kg
Mounting torque	3 Nm (+1/0) with screw M5

● VA11-AP8/C-29S

Weight	1,00 Kg
Mounting torque	3 Nm (+1/0) with screw M5

● VA11-BP7/C-29S

Weight	1,00 Kg
Mounting torque	3 Nm (+1/0) with screw M5

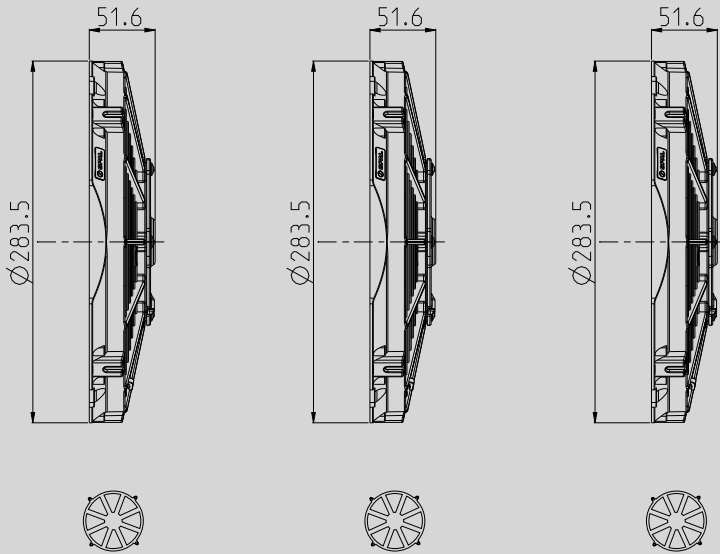

VA11-BP7/C-29S

VA11-BP12/C-29S

pressure [Pa]	VA11-BP7/C-29S		VA11-BP12/C-29S	
	airflow [m³/h]	current input [A]	airflow [m³/h]	current input [A]
0	1.368	4,6	1.264	3,7
25	1.291	4,7	1.179	3,8
50	1.203	4,8	1.088	3,9
75	1.120	4,8	994	3,9
100	1.035	4,8	898	4,0
125	917	4,8	695	4,0
150	727	4,9	477	4,0
175	537	5,0	274	3,9
200	325	4,8	142	4,0
225	208	4,8	0	4,1
250	84	4,9		
275	0	5,0		
300				
325				

## AXIAL FAN PERFORMANCE CURVE

