

## PB SVH 112

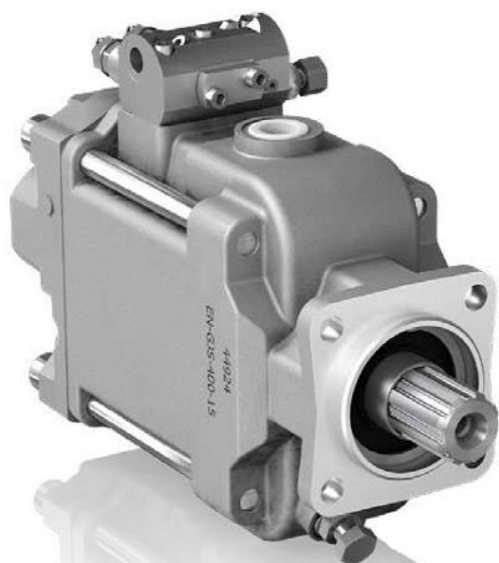

The Sunfab variable displacement pump with its rugged construction is designed for direct mounting at the auxiliary drive (P.T.O.) of commercial vehicles.

With a max. displacement of 130 cm<sup>3</sup>/rev. and a peak pressure of 450 bar it is suited for many applications. This is complemented by the high self priming rate and the low noise level. The pump delivery flow is dependent on the present drive speed and geometric displacement. The flow is adjustable in a range between 0 and Q<sub>max</sub>.

Long service life is ensured due to the pressurized lubrication of the swash plate bearing shell.

Sunfab SVH is rotation-direction dependent and should be ordered in either right-hand or left-hand designs.

### Other advantages of Sunfab SVH:

- Short reaction time when resetting the flow
- Compact installation dimensions
- High working pressure level allowed
- Externally drained for best cooling
- Rugged construction and long service life
- Low noise emission
- High power-to-weight-ratio

### Max. permissible drive/output torque

Description		Nominal size			
		062	092	112	130
Spline shaft D	Drive/output	530 Nm/100 Nm	800 Nm/600 Nm	800 Nm/600 Nm	800 Nm/700 Nm
Spline shaft M	Drive/output	--	530 Nm/530 Nm	530 Nm/530 Nm	--
Spline shaft H	Drive/output	210 Nm/100 Nm	--	--	--
Spline shaft U	Drive/output	210 Nm/100 Nm	--	--	--
Spline shaft T	Drive/output	340 Nm/100 Nm	--	--	--
Spline shaft S	Drive/output	530 Nm/100 Nm	640 Nm/600 Nm	640 Nm/600 Nm	640 Nm/640 Nm
Spline shaft Q	Drive/output	--	900 Nm/600 Nm	900 Nm/600 Nm	900 Nm/700 Nm

## Flange versions (output side)

Coding, SVH			Flange	Shaft
062	092, 112	130		
<b>C 001</b>	<b>C 002</b>	<b>C 003</b>	Prepared for thru-shaft (cover)	
<b>C 010</b>	--	<b>C 030</b>	ISO 7653-1985	DIN ISO 14
<b>C 011</b>	<b>C 021</b>	<b>C 031</b>	SAE-A 2-hole J 744 82-2 ISO 3019-1	SAE-A J 744 (16-4 ISO 3019-1) 9T 16/32 DP
<b>C 012</b>	<b>C 022</b>	<b>C 032</b>	SAE-A 2-hole J 744 82-2 ISO 3019-1	SAE-A J 744 (16-4 ISO 3019-1) 1) 9T 16/32 DP
<b>C 013</b>	--	--	SAE-A 2-hole J 744 82-2 ISO 3019-1	19-4 ISO 3019-1 11T 16/32 DP
<b>C 014</b>	<b>C 024</b>	<b>C 034</b>	SAE-B 2-hole J 744 101-2 ISO 3019-1	SAE-B J 744 (22-4 ISO 3019-1) 13T 16/32 DP
--	<b>C 026</b>	<b>C 036</b>	SAE-B 2-hole J 744 101-2 ISO 3019-1	SAE-BB J 744 (25-4 ISO 3019-1) 15T 16/32 DP
<b>C 015</b>	<b>C 025</b>	<b>C 035</b>	SAE-B 4-hole J 744 101-4 ISO 3019-1	SAE-B J 744 (22-4 ISO 3019-1) 13T 16/32 DP
--	<b>C 027</b>	<b>C 037</b>	SAE-C 2-hole J 744 127-2 ISO 3019-1	SAE-C J 744 (32-4 ISO 3019-1) 14T 12/24 DP
--	<b>C 028</b>	<b>C 038</b>	SAE-C 4-hole J 744 127-4 ISO 3019-1	SAE-C J 744 (32-4 ISO 3019-1) 14T 12/24 DP

<sup>1)</sup> ANSI B 92.1, FLAT ROOT SIDE FIT, spline width deviating from the standard, s = 2.357-0.03

Attention: Observe the max. drive torque rating!

Note: An additional support has to be provided in case of pump combinations. Additional versions on request!

## Description of the controllers

LSP	Load-Sensing controller with integrated pressure limitation
P	Pressure controller, adjustable directly at the pump. The Pressure controller automatically maintains a constant system pressure independent of the required flow. Therefore it is suited for constant pressure systems, where differing flow is required or as efficient pressure limitation of the hydraulic system
Intermediate plates	Intermediate plate only in combination with controllers LSP or P
/ZL	SVH 062, 092, 112: Intermediate plate with power controller (torque limitation) Product "Pressure x Displacement" = constant Adjustment range: 25...100% of max. drive torque Factory setting: 200 Nm
/ZW	Angled intermediate plate (45°) mandatory for mounting controllers at pumps with housing design -2, -3
/L	SVH 130: Power controller (torque limitation), default option Adjustment range: 200-700 Nm Factory setting: 700 Nm

# PB SVH 112



**Controller**  
Coding /LSP, P

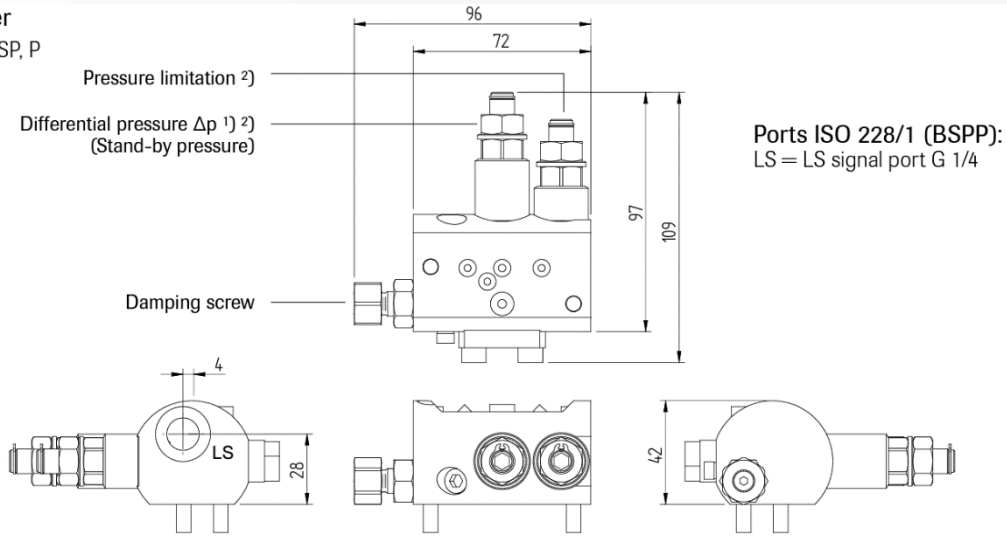

**Intermediate plate**  
Coding /ZW version with thru-shaft

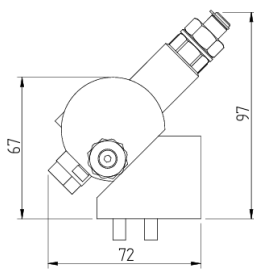

**Controller**  
Coding /ZL intermediate plate version

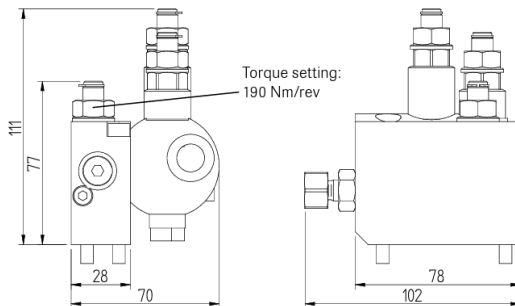

**Controller**  
Coding /L

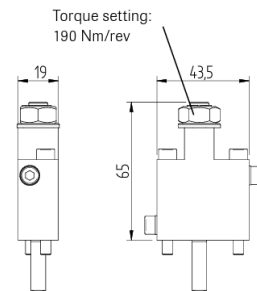

Pressure adjustment	Pressure range (bar)	Δp (bar)/rev.	Pressure setting, factory set (bar)
Pressure limitation	20 ... 400	50	350
Differential pressure Δp	20 ... 55	10	27

1) Applies only coding LSP. 2) The adjustment range is limited by a mechanical stop. **Attention:** Always use a pressure gauge when changing the pressure setting!

**Coding LSP**

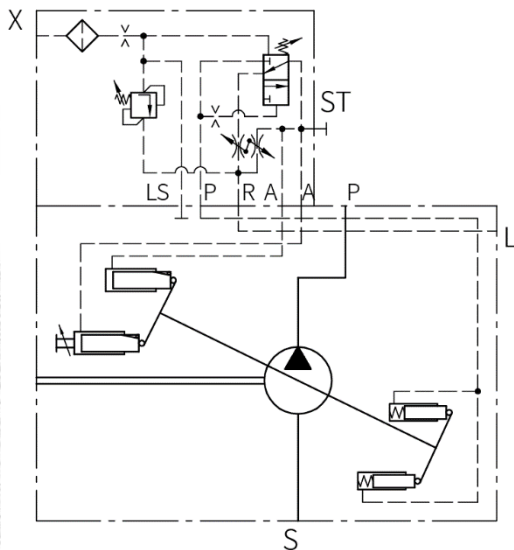

**Coding P**

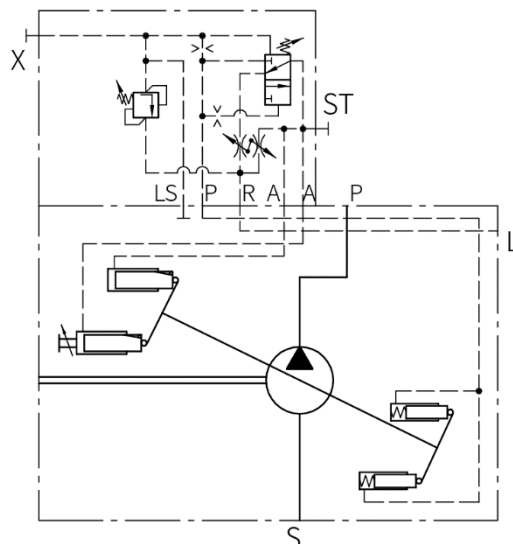

Coding .../ZL

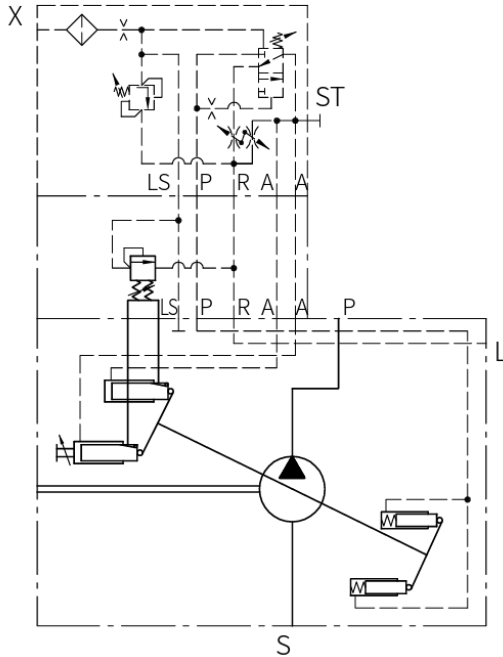

Coding .../L  
for SVH 130

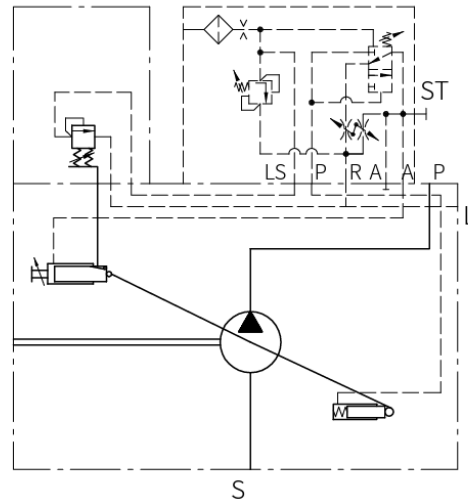

## Additional parameter, general

Calculation of the nom. sizes:

Flow rate

$$Q = \frac{V_g \times n \times \eta_v}{1000} \text{ (lpm)}$$

Torque

$$M = \frac{1,59 \times V_g \times \Delta p}{100 \times \eta_{mh}} \text{ (Nm)}$$

Power

$$P = \frac{2\pi \times M \times n}{60000} = \frac{M \times n}{9549} = \frac{Q \times \Delta p}{600 \times \eta_t}$$

$V_g$  Displacement (cm<sup>3</sup>/rev.)

$\Delta p$  Differential pressure (bar)

$n$  Speed (rpm)

$\eta_v$  = Volumetric efficiency

$\eta_{mh}$  = Mechanical-hydraulic efficiency

$\eta_t$  = Total efficiency ( $\eta_t = \eta_v \times \eta_{mh}$ )

**Nomenclature**

**Mounting**

**Surface**

**Direction of rotation**

**Changing the rotation direction**

**Installed position**

**Hydraulic fluid**

**Temperature**

**Filtration**

Axial piston pump according to the swash plate principle

At the auxiliary drive of commercial vehicles

(flange ISO 7653-1985 for trucks) or flange assembly

(flange ISO 3019-2 or SAE/ISO 3019-1)

Painted, RAL 7043 (Traffic grey)

Right or left

Contact Sunfab

Any (observe the installation instructions)

Hydraulic oil acc. to DIN 51524 part 1 to 3; ISO VG 10 to 68 acc. to DIN 51519

Viscosity range: min. approx. 10; max. approx. 1000 mm<sup>2</sup>/sec

Optimal operation range: approx. 20...50 mm<sup>2</sup>/sec. Also suitable are biologically degradable pressure fluids type HEES (synth. Ester) at operation temperatures up to approx. +70 °C.

Ambient: approx. -40...+60 °C

Fluid: -25...+80 °C, pay attention to the viscosity range!

Start temperature down to -40 °C is allowable (Pay attention to the viscosity range during start!), as long as the operation temperature during subsequent running is at least 20 °C higher.

Should conform to ISO standard 4406 code 21/18/15 ...19/17/13

## Curves

### Flow and Power

Charts show flow/pressure (without controller). Power at max. setting angle and power at min. setting angle and 1500 rpm

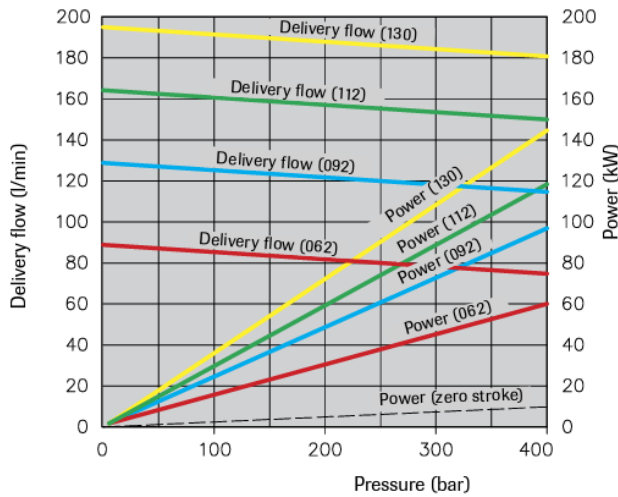

**Inlet pressure (LSP-controller)**  
Graph valid at viscosity 75 mm<sup>2</sup>/s at max. setting angle.

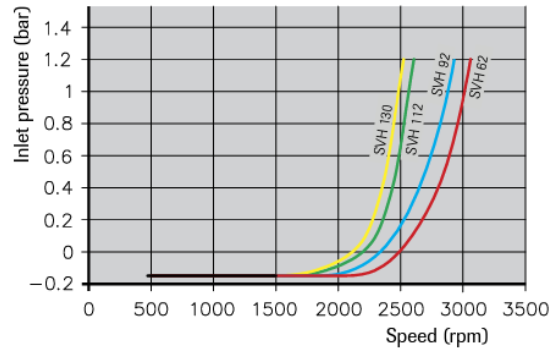

### Controller curve

Coding **L**

**Pressure / Delivery flow**

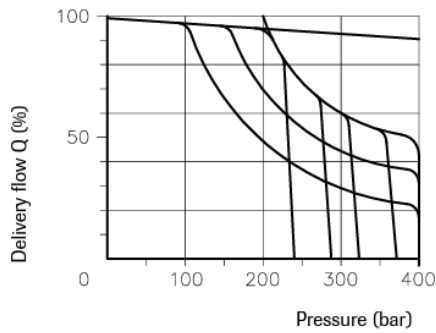

### Response time T<sub>1</sub> (LSP-controller)

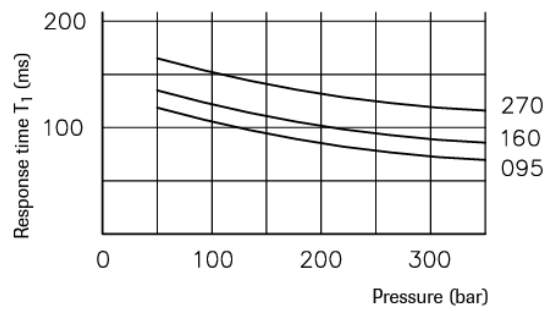

Coding **LSP**

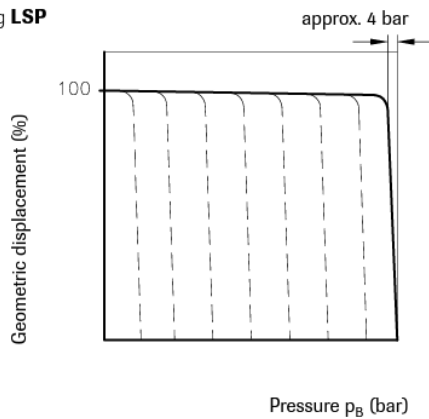

### Response time T<sub>2</sub> (LSP-controller)

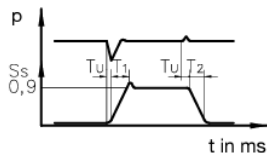
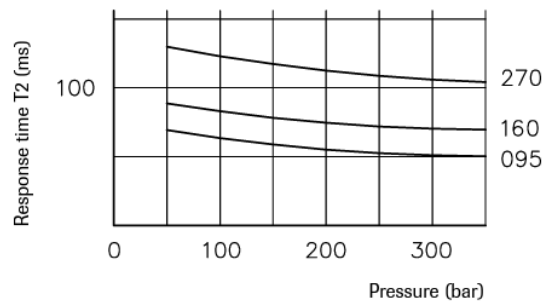

Ss = Regulating distance actuator  
Tu = Delay < 3 ms  
T1 = Response time min to max  
T2 = Response time max to min  
p = Pressure

LS-line min. length 1.5 m, min. internal diameter 12 mm



# PB SVH 112



## Additional input shaft designs

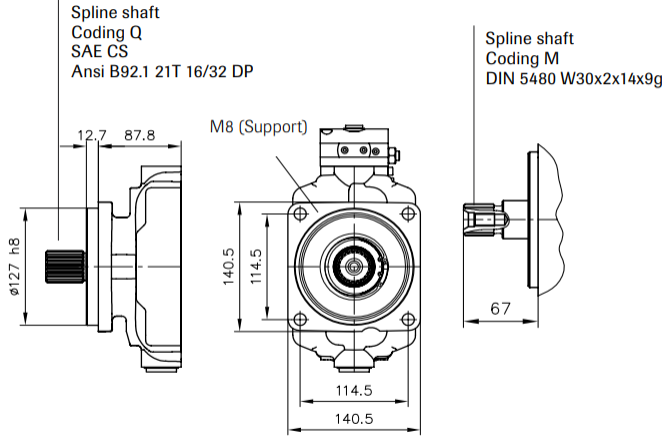

## Additional mounting flange design

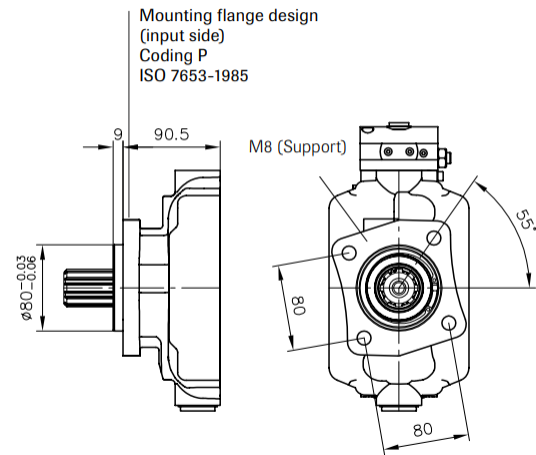

## SVH 112 with thru-shaft

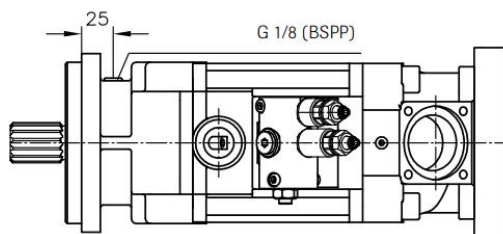
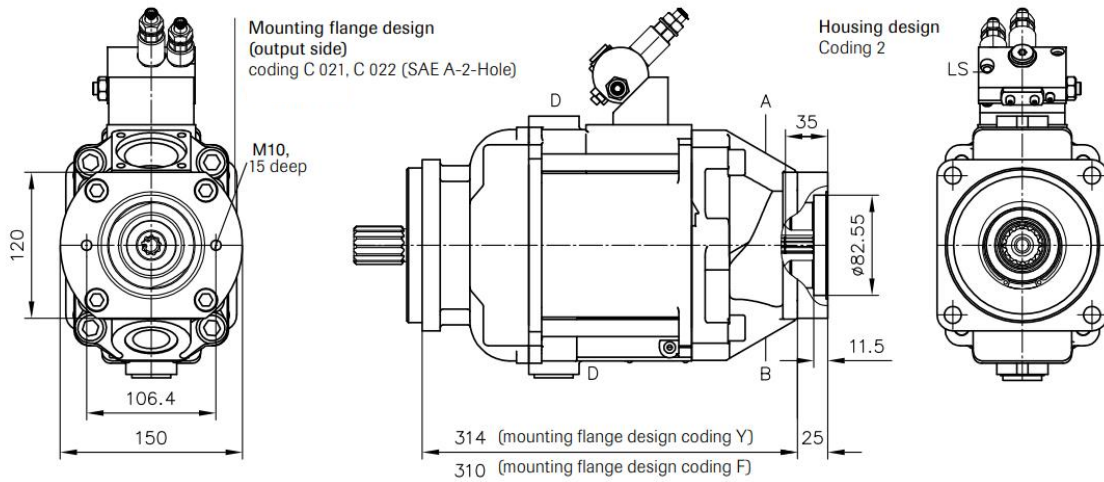

Suction port A

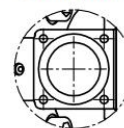

Right hand

A Suction port

B Pressure outlet

Pressure outlet B



Left hand

A Pressure outlet

B Suction port

# PB SVH 112

