

Cylinder 5 stage front end with plain eye

CS18LE57483S70A02

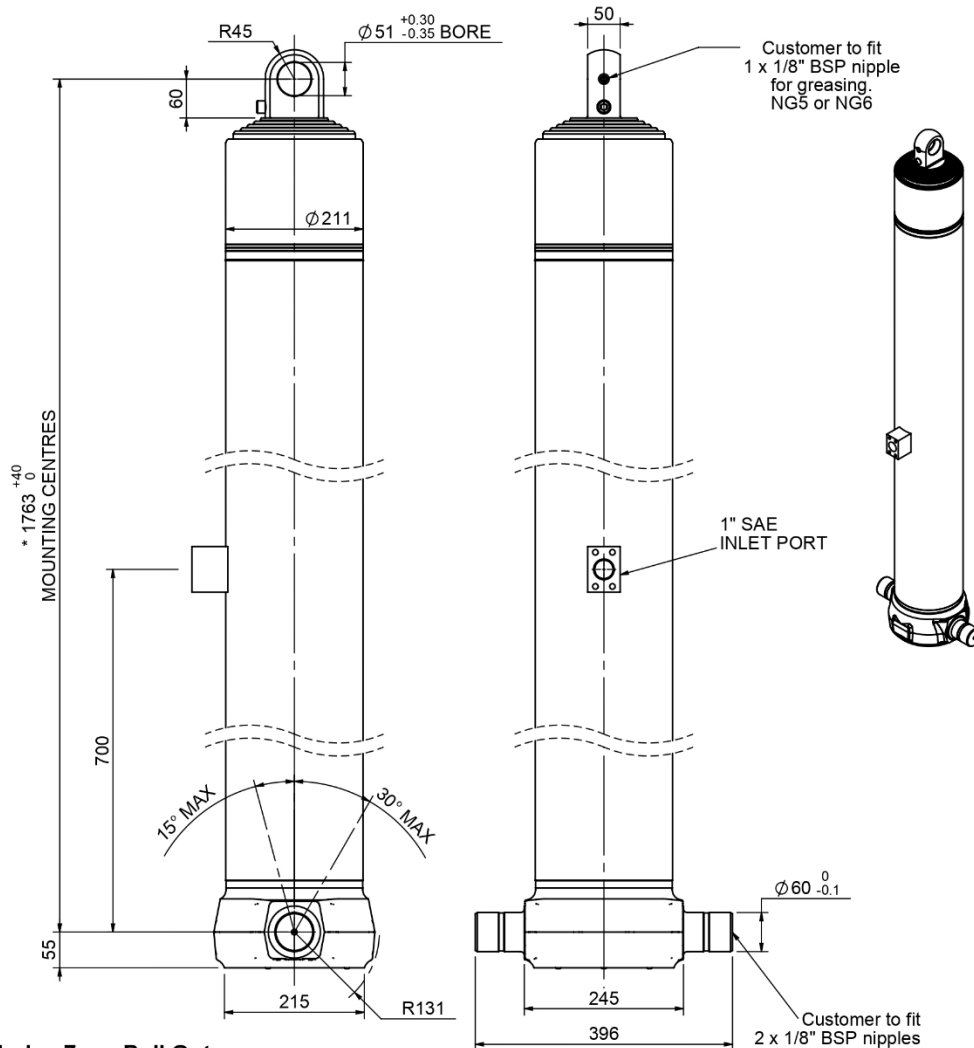

***Includes 7mm Pull Out. Last Stage Chrome Plated**

SPECIFICATION TIPPING CAPACITY : 28-37 TONNES***

Stage	Diameter	Length	Stroke	Swept Volume
-	-	-	-	-
0	211	1725	-	-
1	188	1690	1470	41
2	167	1690	1487	33
3	147	1690	1497	25
4	127	1690	1512	19
5	105	1690	1517	13
Total (+5/-10)			7483	131
Final stroke reduced by	0	Priming Volume		24.3
Cylinder Mass (Kg)	285	Total Volume (Litres)		155.3
Maximum Pressure (Bar)	190	Max. first stage thrust		200 KN

*****TIPPING CAPACITY AT WORKING PRESSURE**

BODY LENGTH (BL)						OH
9250		9750		10250		
31	49°	29	47°	28	44°	150
33	51°	31	48°	30	46°	450
37	53°	34	50°	32	47°	750

d = 0; r = 900; Working Pressure 120 bar

Tipping angle (θ)
Body + payload mass, W (tonne)

For guidance only;
Higher working pressures and tipping capacities may be possible.
To check your application email - applications@edbro.co.uk

NOTES

1. This cylinder is for lifting purposes only and side load conditions should be avoided
2. Cylinder is painted in primer paint to RAL5013
3. Refer to www.edbro.com for;-
 - Bracket details
 - Installation instructions that must be observed
 - Correct oil selection
 - An explanation of tipping capacity