

Cylinder 5 stage front end with outer cover

** ALLOW 50mm TO REMOVE CAP FOR SERVICING

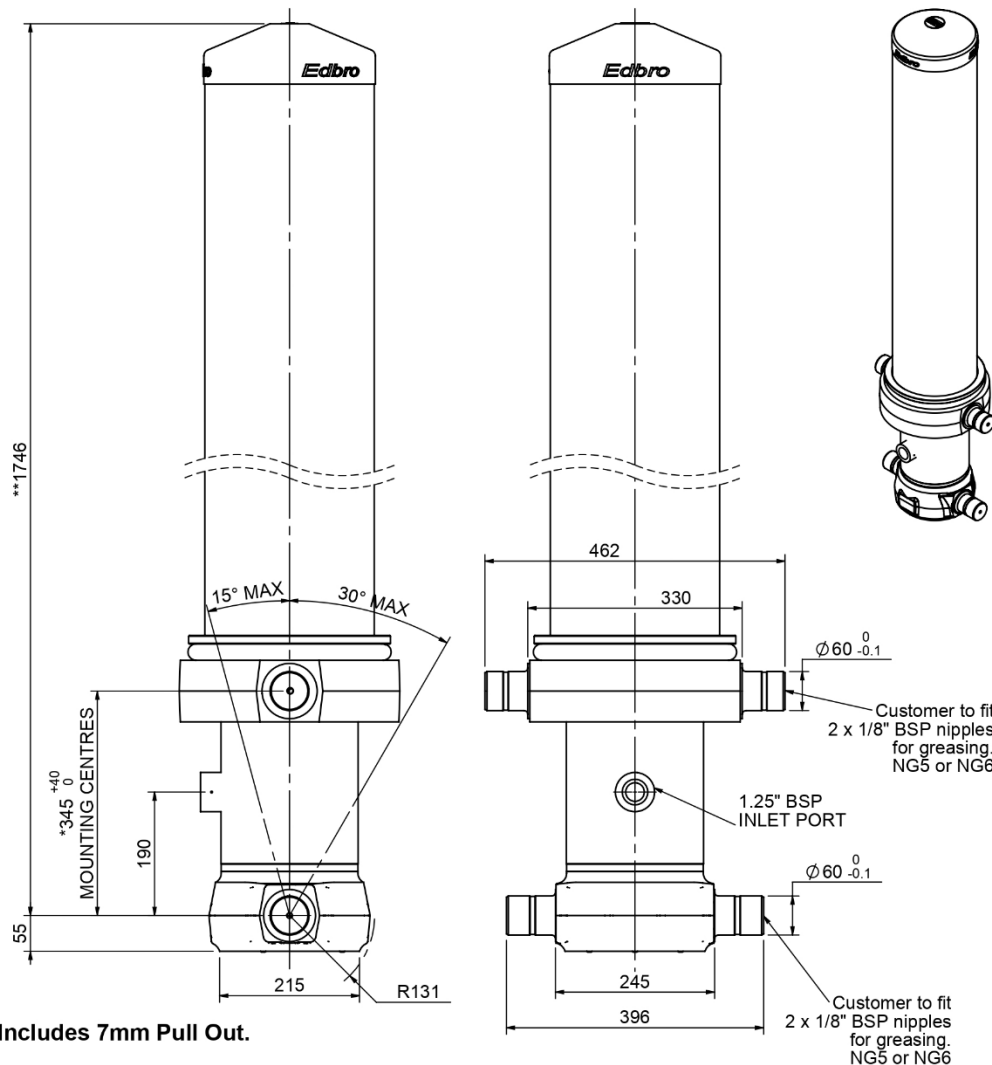

CS18L057233B19A11

SPECIFICATION TIPPING CAPACITY : 34-46 TONNES***

Stage	Diameter	Length	Stroke	Swept Volume
OUTER COVER	261	1365	-	-
0	211	1675	-	-
1	188	1640	1420	39
2	167	1640	1437	31
3	147	1640	1447	25
4	127	1640	1462	19
5	105	1640	1467	13
Total (+5/-10)			7233	127
Final stroke reduced by	0	Priming Volume		23.5
Cylinder Mass (Kg)	351	Total Volume (Litres)		150.5
Maximum Pressure (Bar)	190	Max. first stage thrust		200 KN

*****TIPPING CAPACITY AT WORKING PRESSURE**

BODY LENGTH (BL)					OH	
8500		9000		9500		
38	50°	36	47°	34	45°	150
41	52°	38	49°	36	46°	450
46	54°	42	51°	39	48°	750

d = 229; r = 900; Working Pressure 135 bar
 Tipping angle (θ)
 Body + payload mass, W (tonne)

For guidance only;
 Higher working pressures and tipping capacities may be possible.
 To check your application email - applications@edbro.co.uk

NOTES

1. This cylinder is for lifting purposes only and side load conditions should be avoided
2. Cylinder is painted in primer paint to RAL5013
3. Refer to www.edbro.com for;-
 - Bracket details
 - Installation instructions that must be observed
 - Correct oil selection
 - An explanation of tipping capacity