

**PB 09302600059**



**ALBERO DI CORREDO  
QUILL SHAFT  
"AT 2412C...ATO 3112C  
CON E SENZA RETARDER"**

**CODICE  
CODE**

**09302600059**

**VOLVO**

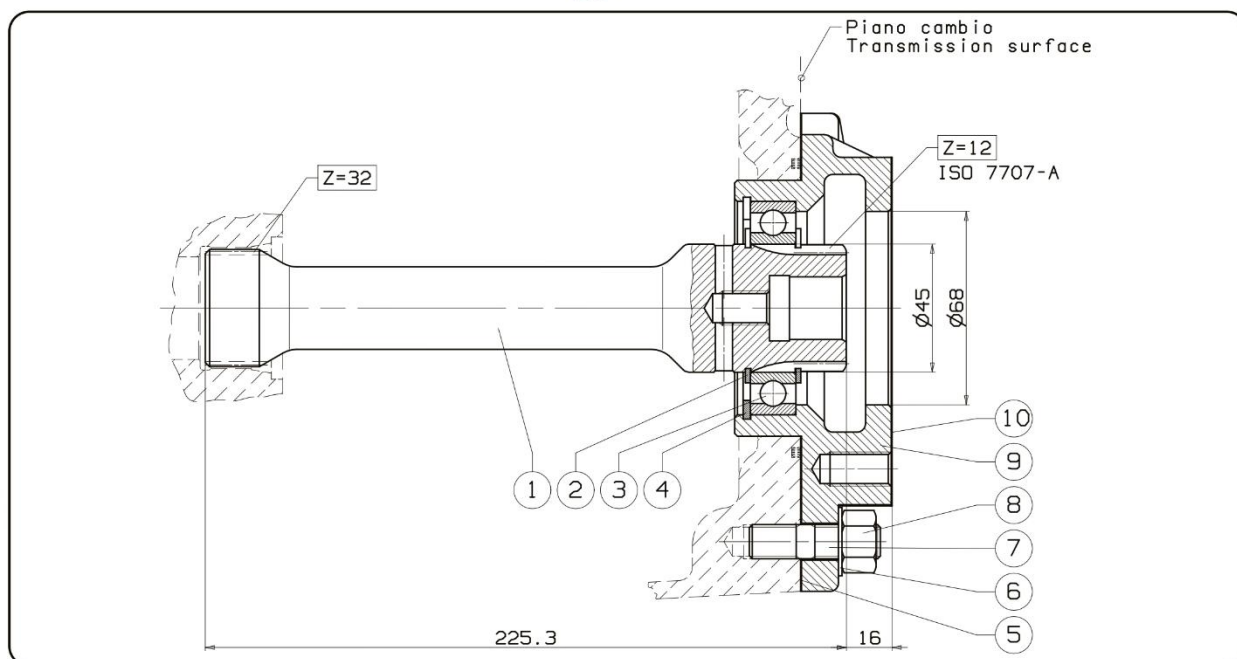

N°	Descrizione Description	Q.
1	Albero di corredo / Quill shaft	1
2	Anello elastico / Circlip E 45	2
3	Cuscinetto a sfere / Ball bearing 45x75x16	1
4	Anello elastico / Circlip I 75	1
5	Guarnizione / Gasket	1
6	Rondella elastica ondulata / Washer	4
7	Prigioniero / Stud bolt M12x27	4
8	Dado / Nut M12 CH17 H12	4
9	Flangia di accoppiamento pto/cambio / Shift-PTO coupling flange	1
10	Guarnizione / Gasket	1