

**PB 01606200173**



**PRESA DI FORZA A  
COMANDO PNEUMATICO  
"POWER-TRUCK"**

**PNEUMATIC CLUTCH POWER TAKE-OFF**

**CODICE PTO  
PTO CODE**

**16-61/62/63**

**CAMBIO  
GEARBOX**

**MERCEDES  
G 56-6**



**DIAGRAMMA DI UTILIZZO  
WORKING CONDITION**

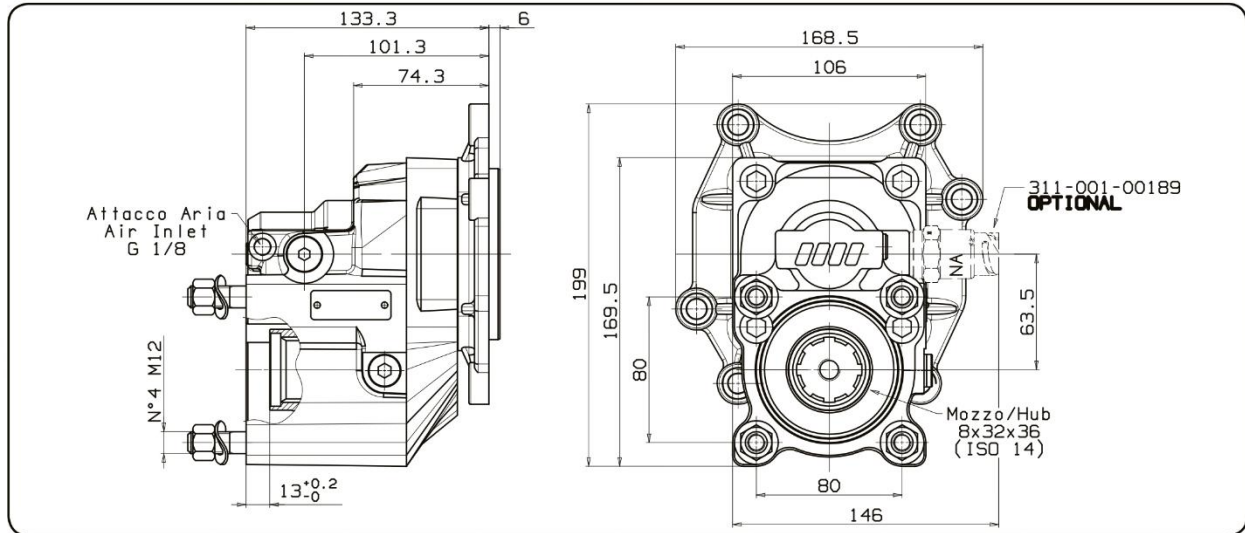
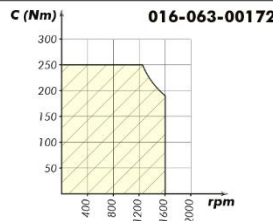
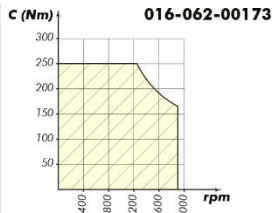

| Tipo cambio<br>Gearbox | Codice PTO<br>PTO code | Versione<br>Version | Rapporto interno<br>Internal ratio | Giri pto a<br>1000 giri<br>motore<br>Pto ratio@1000<br>eng.rpm<br>rpm | Coppia massima<br>Max torque<br>Nm | Lato<br>montaggio<br>Mounting side | Uscita<br>Output | Rotazione<br>Rotation | Kit di<br>montaggio<br>Mounting<br>kit | Peso<br>Weight<br>Kg |
|------------------------|------------------------|---------------------|------------------------------------|-----------------------------------------------------------------------|------------------------------------|------------------------------------|------------------|-----------------------|----------------------------------------|----------------------|
| G 56-6                 | 16-61-174              | 17                  | 1:1,81                             | 1015                                                                  | 300                                | Poster.<br>Rear                    | Poster.<br>Rear  | Ant.<br>Acw           | 154-3-3517                             | 9,8                  |
|                        | 16-62-173              |                     | 1:1,53                             | 855                                                                   | 250                                |                                    |                  |                       |                                        |                      |
|                        | 16-63-172              |                     | 1:1,31                             | 732                                                                   |                                    |                                    |                  |                       |                                        |                      |