

PB 01601800177



**PRESA DI FORZA A
COMANDO PNEUMATICO**
PNEUMATIC CLUTCH POWER TAKE-OFF

CODICE PTO
PTO CODE **16-18-177**

CAMBIO
GEARBOX **MERCEDES**



DIAGRAMMA DI UTILIZZO
WORKING CONDITION

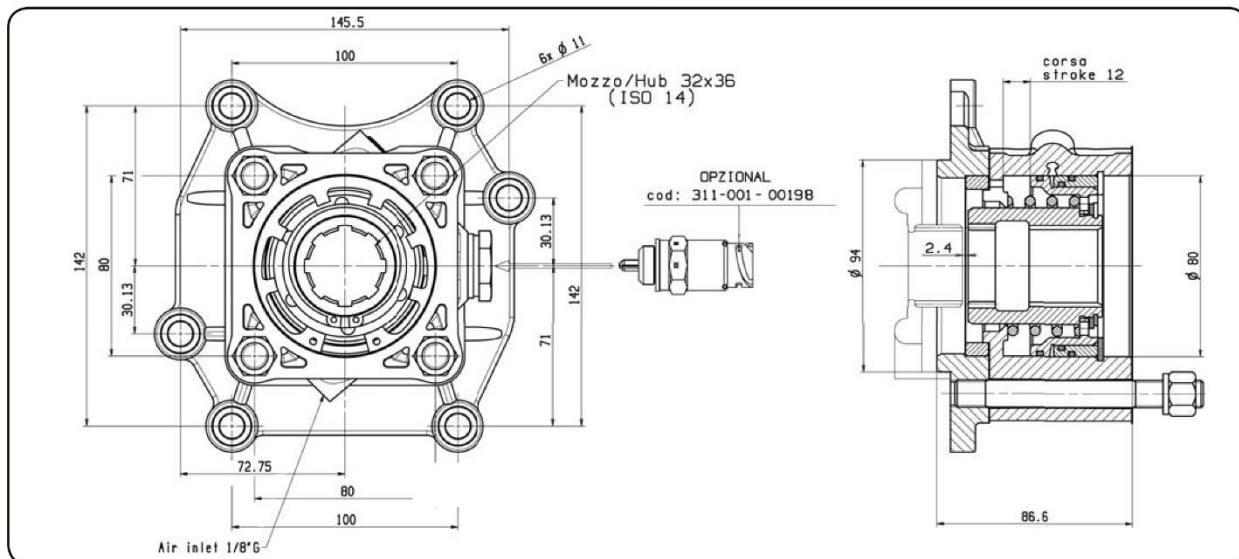
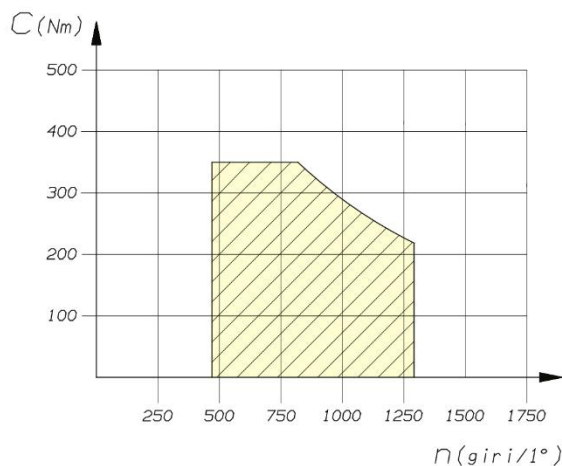

Tipo cambio Gearbox	Codice PTO PTO code	Versione Version	Giri pto a 1000 giri motore Pto ratio@1000 eng.rpm	Coppia massima Max torque	Lato montaggio Mounting side	Uscita Output	Rotazione Rotation	Kit di montaggio Mounting kit	Peso Weight
			rpm	Nm					kg
G 56	16-18-177	17	560	350	Post. Rear	Poster. Rear	Oraria Cw	154-3-3517	4