

1 OIL CAP FLANGE

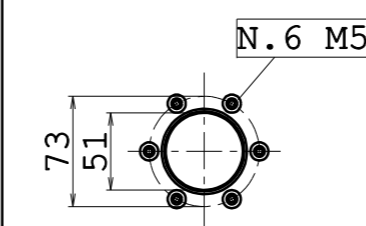

SCALE 1:2,5

2 RETURN FILTER FLANGE

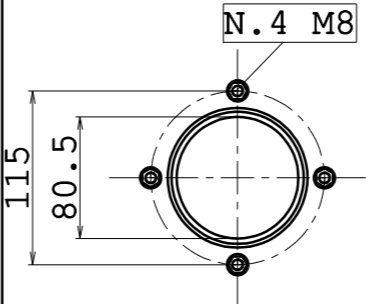

SCALE 1:2,5

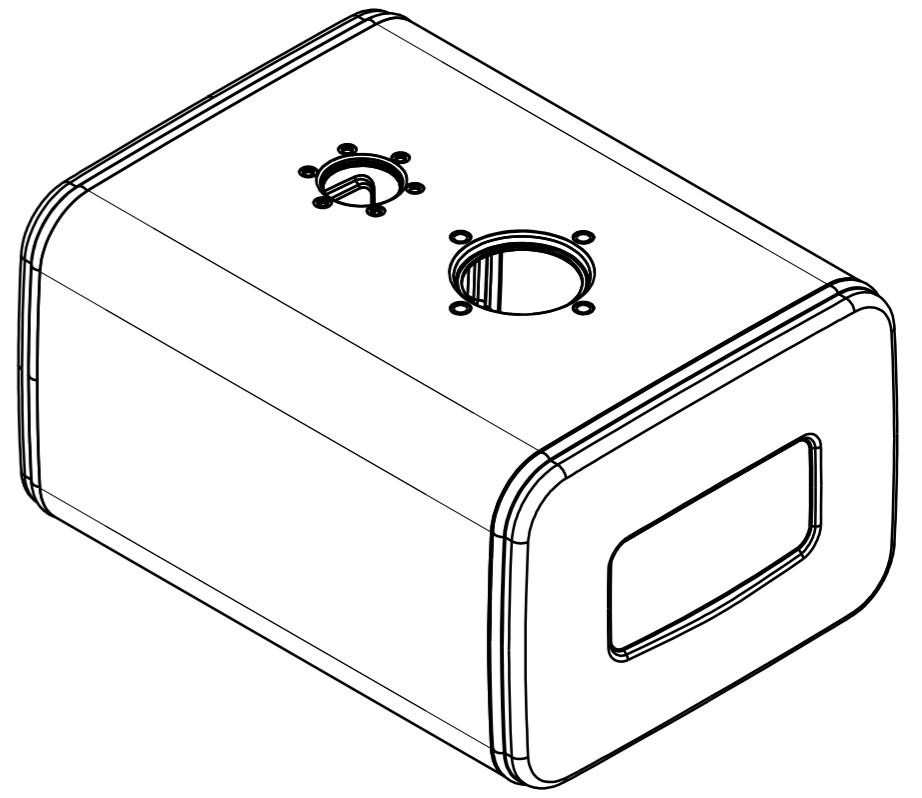

Tank composition

Pos.	Denominazione	Q.tà
1	OIL CAP FLANGE	1
2	RETURN FILTER FLANGE	1
3	OIL SUCTION CONNECTION 1" 1/4	1
4	3/4" LEVEL INDICATOR	1

Tank dimension

Level indicator capacity	40 Lt
Full capacity	50 Lt
Support weight	
Tank weight (F,I,T)	kg (A) kg
Dimensions	565x260x360 mm

0	EMISSIONE	08/11/2018	FG	MM	EB
Rev.	Modify description	Date	Des.	Ver.	App.
Part name :	Oil tank 50 LT Aluminium fam. 260x360				
Part code :	NSOA0050056H000	Replace the	Material code		
Scale	1:5	Replaced by	(X)=A:Aluminium EN AW 5754 UNI 573-3		
			General tolerances: ISO 2768 V		
			Drawing format A3		
			OWNERSHIP OF THIS DRAWING IS RESERVED BY LAW AND MAY NOT BE REPRODUCED IN WHOLE OR IN PART WITHOUT PERMISSION OF PADOAN S.R.L.		
			DO NOT MAKE MEASUREMENTS ON DRAWING DO NOT CHANGE WITHOUT TECHNICAL OFFICE AUTHORIZATION		

