

MI 13590101012

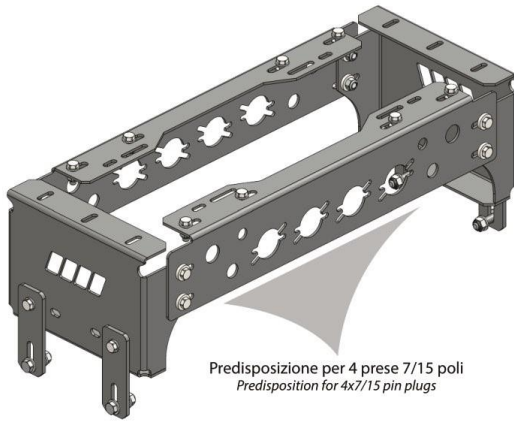

Predisposizione per 4 prese 7/15 poli
 Predisposition for 4x7/15 pin plugs

Esempio montaggio
 Mounting example

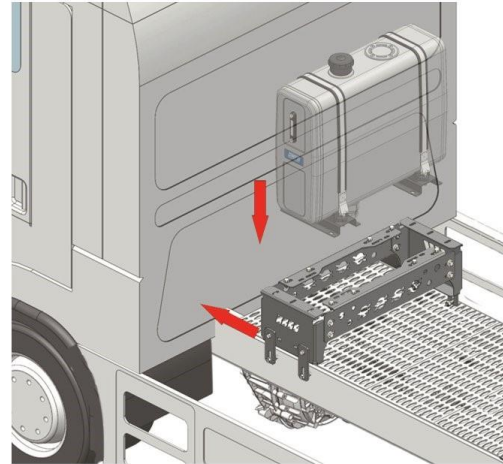

Ingombro / Dimensions

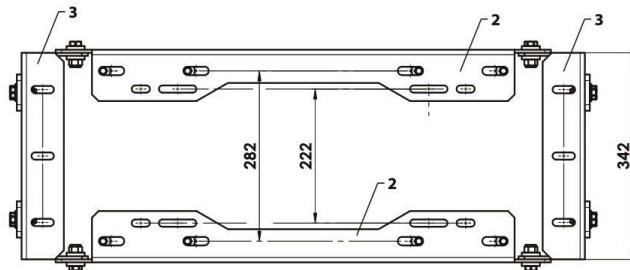
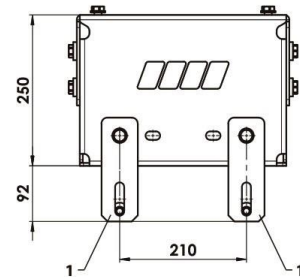
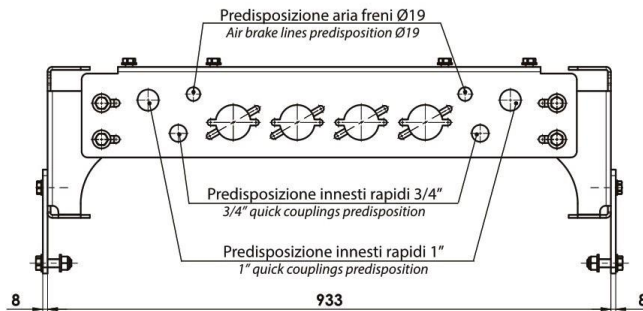

RICAMBI / SPARE PARTS		
Codice / Code	Descrizione / Description	Q.
1 53800403950	Staffa fissaggio supporto a telaio - Cataforesi nera Chassis mounted oil tank frame - Black KTL treatment	4
2 53800403969	Staffa laterale - Verniciatura grigia RAL 7021 Side bracket - Gray RAL 7021 powder coating	2
3 53800403987	Staffa frontale - Verniciatura grigia RAL 7021 Front bracket - Gray RAL 7021 powder coating	2
13590100728	Kit fissaggi completo / Fixing complete kit	

MI 13590101012

Dettaglio fissaggi / / Fixing detail

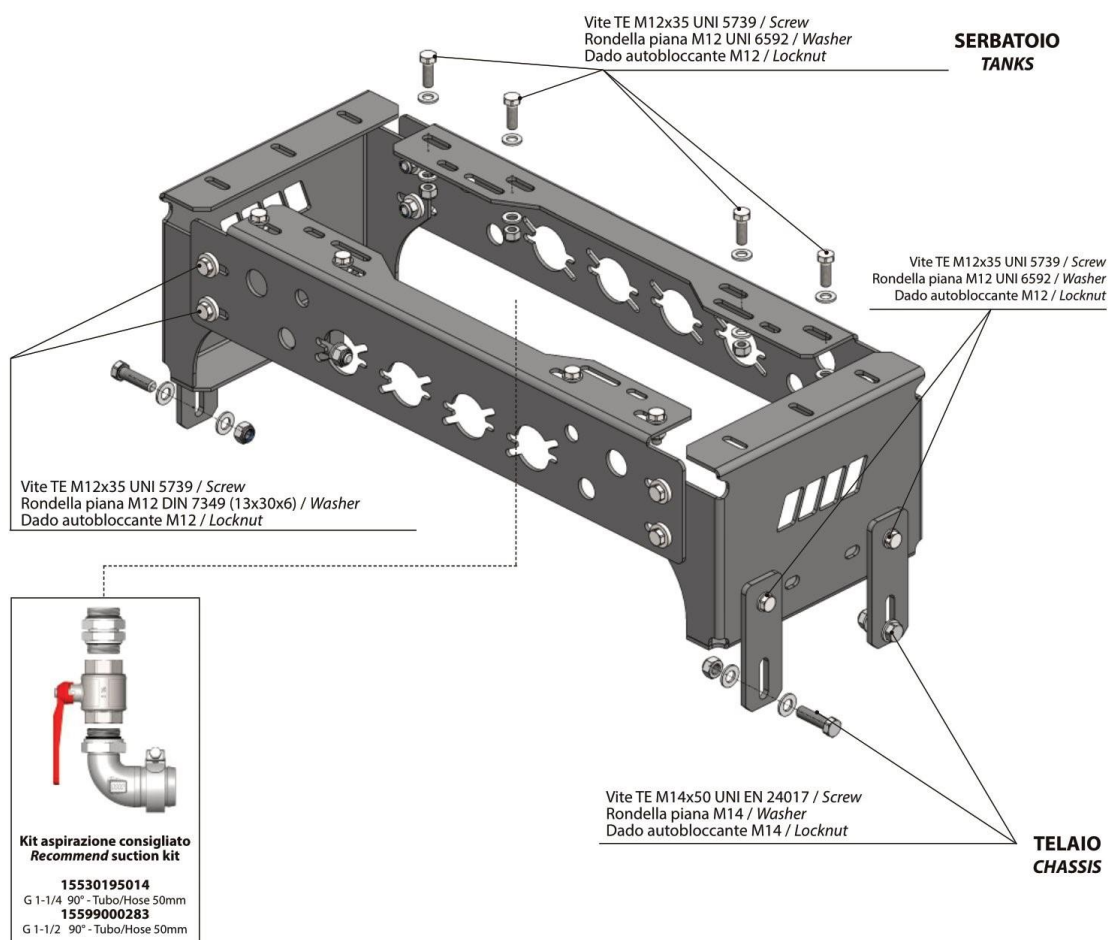

Esempi installazione / / Installation examples

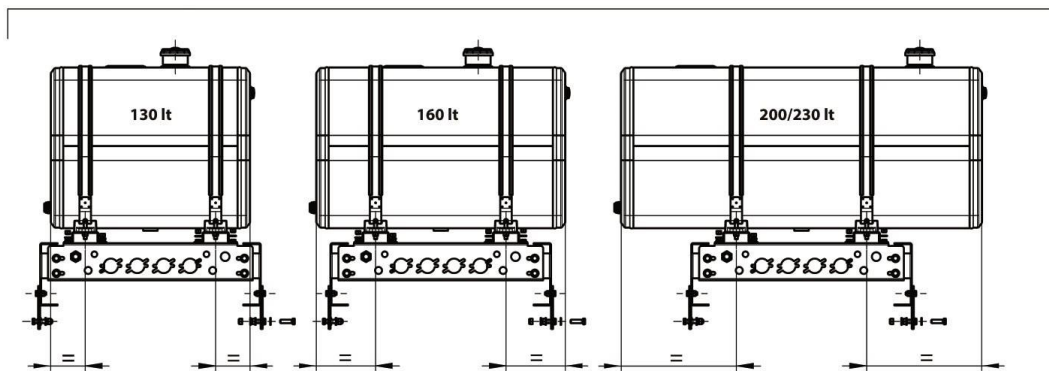

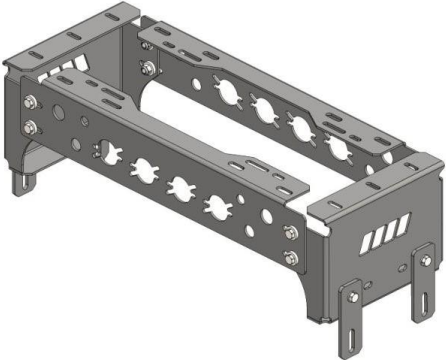
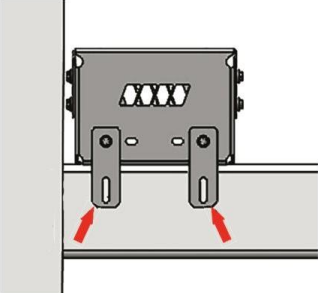
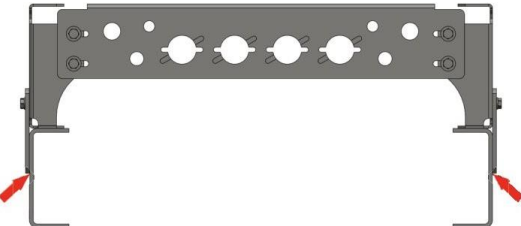
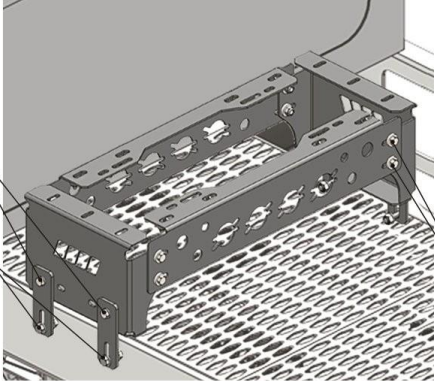
	<p>Montare il telaio con le 12 viti (M12x35) indicate in figura, SENZA serrarle completamente.</p> <p><i>Fix the frame with the 12 screws M12x34 shown in the picture, DON'T tighten them completely.</i></p>
	<p>Montare il telaio sul veicolo facendo attenzione che le 4 staffe indicate siano in posizione il più possibile verticale, accoppiandosi con i fori presenti sul longherone.</p> <p><i>Fix the frame onto the vehicle making sure the 4 indicated brackets are in vertical position as much as possible and that they match the 4 holes of vehicle's side member.</i></p>
	<p>Controllare inoltre che le staffe siano completamente a contatto con il fianco del longherone stesso.</p> <p><i>Make sure the 4 brackets are well in contact with the side of the side member.</i></p>
<div style="display: flex; flex-direction: column;"> <div style="margin-bottom: 10px;"> <p>2</p> <p>Vite/Screw TE M12x35 UNI 5739 Coppia di serraggio/Tightening torque 80 Nm</p> </div> <div style="margin-bottom: 10px;"> <p>1</p> <p>Vite/Screw TE M14x50 UNI EN 24017 Coppia di serraggio/Tightening torque 120 Nm</p> </div> </div> 	<p>Serrare definitivamente le viti del telaio supporto come indicate IN SEQUENZA 1 2 3, con le relative coppie di serraggio.</p> <p>Procedere quindi al montaggio del serbatoio.</p> <p><i>Tighten fully the frame screws following indicated SEQUENCE 1 2 3, and related tightening torques.</i></p> <p><i>Place and fix the oil tank to the frame.</i></p> <div style="margin-top: 20px;"> <p>3</p> <p>Vite/Screw TE M12x35 UNI 5739 Coppia di serraggio/Tightening torque 80 Nm</p> </div>



ATTENZIONE: tutte le operazioni relative al montaggio, devono essere eseguite **IN SICUREZZA** secondo le norme vigenti.
ATTENTION: all the operations related to the assembling of these components have to be carried out in respect of the current **SAFETY** regulations in place.