

UT Series Tipping Valve – Single & Dual Pressure

Single & Dual Pressure



UT201 Single Pressure

UT201 Dual Pressure

Part number

UT20x

Pump Inlet

Pressure (Bar)

P /

M = 6mm air
E = 1/4" mm air

075 = 3/4" BSP
100 = 1" BSP

Pressure setting 165, 175, 190, 220
No cartridge fitted 000
Dual pressure 175/250

- Fully proportional - excellent lowering control when loaded
- No system filtration required
- High flow capacity for reduced cycle times
- Compact and lightweight
- Interchangeable with previous CT valve range
- Multiple mounting options
- Pressure switch point provided
- Single pressure or Dual pressure relief valve cartridges available
- Adjustable lowering speed
- Tamper proof pressure relief valve

Part number	Description
UT201M075P000	Tip Valve , Ø6mm tube, 3/4"pump inlet & no relief valve
UT201M075P165	Tip Valve , Ø6mm tube, 3/4"pump inlet & 165 bar manual shift relief valve
UT201M075P175	Tip Valve , Ø6mm tube, 3/4"pump inlet & 175 bar manual shift relief valve
UT201E075P175/250	Tip Valve, 1/4" tube, 3/4"pump inlet & 175 / 250 bar manual shift relief valve
UT201M075P190	Tip Valve , Ø6mm tube, 3/4"pump inlet & 190 bar manual shift relief valve
UT201M075P175/250	Tip Valve , Ø6mm tube, 3/4"pump inlet &175 / 250 bar manual shift relief valve
UT201E075P175/250A	Tip Valve, 1/4" tube, 3/4"pump inlet & 175 / 250 bar air shift relief valve
UT201M075P175/250A	Tip Valve , Ø6mm tube, 3/4"pump inlet &175 / 250 bar air shift relief valve
UT201M100P000	Tip Valve , Ø6mm tube, 1"pump inlet & no relief valve
UT201M100P165	Tip Valve , Ø6mm tube, 1"pump inlet & 165 bar manual shift relief valve
UT201M100P175	Tip Valve , Ø6mm tube, 1"pump inlet & 175 bar manual shift relief valve
UT201M100P190	Tip Valve , Ø6mm tube, 1"pump inlet & 190 bar manual shift relief valve
UT201M100P175/250	Tip Valve , Ø6mm tube, 1"pump inlet & 175/250 bar manual shift relief valve
UT201M100P175/250A	Tip Valve , Ø6mm tube, 1"pump inlet & 175/250 bar air shift relief valve

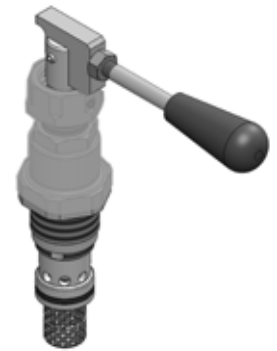

Dual Pressure relief valve
175/250 bar



Single Pressure relief

Replacement pressure relief cartridges

Part number	Description
UTVC110150	Single Pressure Relief Valve Cartridge 150 bar
UTVC110165	Single Pressure Relief Valve Cartridge 165 bar
UTVC110175	Single Pressure Relief Valve Cartridge 175 bar
UTVC110190	Single Pressure Relief Valve Cartridge 190 bar
UTVC110220	Single Pressure Relief Valve Cartridge 220 bar
UTVC175/250	Manual Dual Pressure Relief Valve Cartridge 175/250 bar
UTVC175/250A	Air Shift Dual Pressure Relief Valve Cartridge 175/250 bar

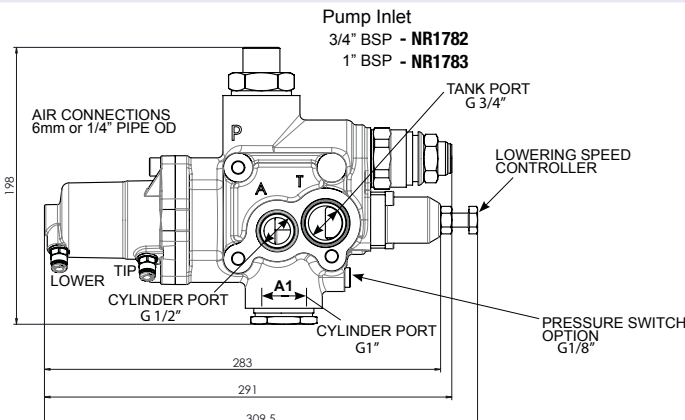

Dual Pressure air operated relief

