

Installation guide SVH

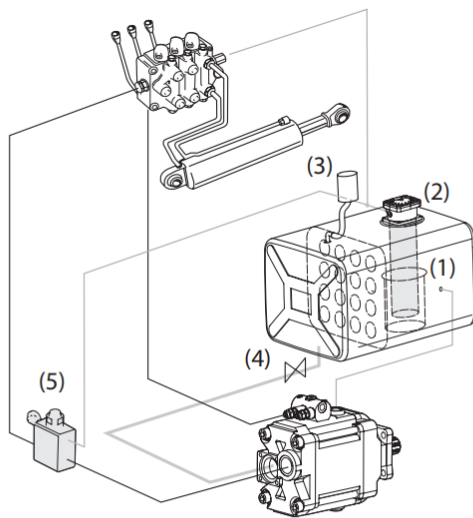
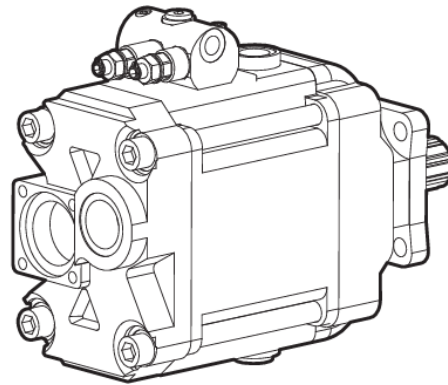

Pump and tank

Pump SVH can be ordered in left or right-hand versions depending on the direction of rotation of the power take off.

The tank must be equipped with oil pipes (1) around the return filter for optimal de-aeration of the oil. The size of the oil filter (2) must correspond to $4 \times$ the effective pump flow with a degree of purification of $10 \mu\text{m}$ absolute. Should the system require cooling for optimal efficiency, a cooler must be placed on the return line or in a separate circuit. The amount of oil in the tank should correspond to the maximum pump flow during 2 minutes. A breather filter (3) of $10 \mu\text{m}$ must be installed so that moisture and contaminants cannot enter the tank. The air flow at 0.1 bar pressure difference should at least be equal to the maximum oil flow.

The tank should be positioned close to the pump on a level so that the lowest oil level does not come below the pump level. Pipes are routed so that air pockets cannot form to prevent cavitation and noise. Any suction shut-off valve (4) must have an internal diameter that is not less than the suction line.

There must be a pressure relief valve (5) in the system. It must be installed close to the pump if there are long pipes to the operating valve.

Pipe dimensions, inside mm (d_i)

Max pump flow l/m	90	120	160	220
Suction-pipe ¹⁾	50	50	63	75
Return line	32	32	38	45
Pressure line	19	25	25	32

¹⁾ If the suction pipe is more than 2 m long the internal diameter must be increased by 10 mm for each meter extension.

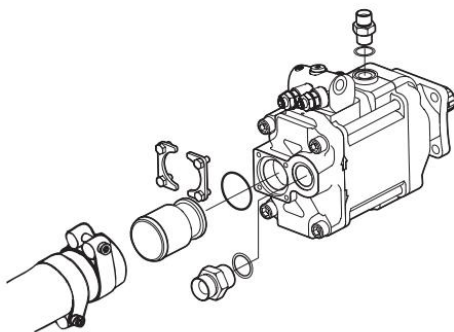

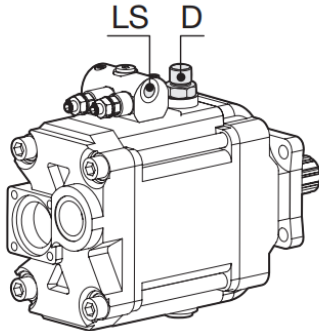

Drainage line D

Route a drainage pipe of at least 19 mm directly between the pump and tank. The drainage pipe's connection to the tank should lie in between the lowest oil level and the bottom of the tank. The pump housing must be filled with new hydraulic fluid before the hydraulic pump is commissioned.

Signal line LS

The capacity of the LS signal line should be adapted to the relevant hydraulic system. The speed and damping for the signal is optimal when the LS signal line has a capacity of 10 % of the capacity for the pressure line between the pump and directional control valve. If both lines are the same length, the inside diameter of the signal line should be 1/3 of the pressure line's internal diameter I.E. 1/4-1/2". The signal line should ideally be a hose.

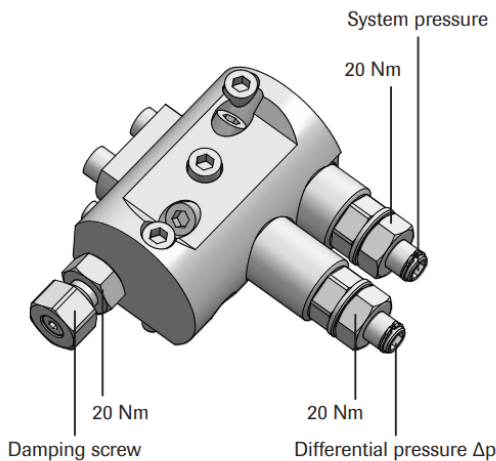

Load sensing regulator LSP

Adjust the differential pressure $\Delta p = \text{system pressure} - \text{signal pressure}$. The regulation range is 20-55 bar. Preset to 27 bar. 1 turn of the adjuster screw corresponds to 10 bar. Clockwise increases the differential pressure, counterclockwise decreases.

Adjust the max. system pressure between 20 and 350 bar. The value preset at the factory is 350 bar. 1 turn of the adjuster screw corresponds to 50 bar. Clockwise increases the maximum system pressure, counterclockwise decreases.

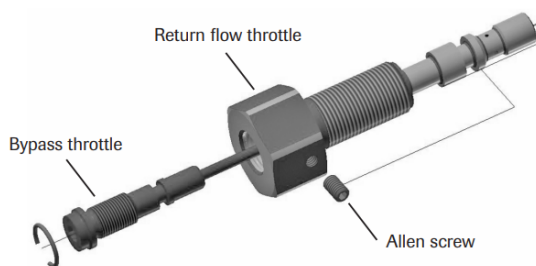

Description of the two-part damping screw on the LSP-controller

With the return flow throttle you can adjust the onstroke time for bringing the pump from V_{gmin} to V_{gmax} .

- Unscrewing the screw reduces the dampening and accelerates the onstroke time.
- Screwing in the screw increases the dampening and slows down the onstroke time.
- Adjustment range: ca. 5.5 revolutions resp. 4 mm

With the bypass throttle you can adjust the destroke time for bringing the pump from V_{gmax} to V_{gmin} .

- Unscrewing the screw increases the dampening and slows down the destroke time
- Screwing in the screw reduces the dampening and accelerates the destroke time
- Adjustment range: ca. 4 revolutions resp. 2 mm